

Full Automatic Mounting Press

B/B-E3

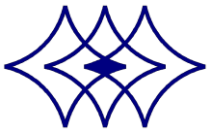



TOP TECH

Instruction



Operation video

Top cover
Quick release



Indicator light
LED display
Mounting completed indicator

Pressure gauge
Pressure display

PCB panel
One button start
Intuitive operation

Filter system
Remove solids
from water

Build-in Buzzer
Remind mounting
finished

Thermostat
Multi over temperature
protections



Water inlet/outlet
Convenient to use



Specialized socket
(For water pump only)
Built-in water recycling system

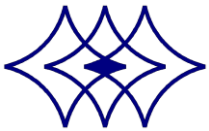

TOP TECH

Features

Pressure gauge



Molds

Ø25

Ø32

Ø40

Ø50

option

Cylinder kit
([Appendix 2](#))



option

Coolant pump



Order no.	Spec.
QWP06001	1Ø-110V-50/60HZ
QWP06002	1Ø-220V-50/60HZ
QWP06002-1	1Ø-200V-50/60HZ

Features

- Memory modes
- Heating temperature
- Heating time
- Cooling time

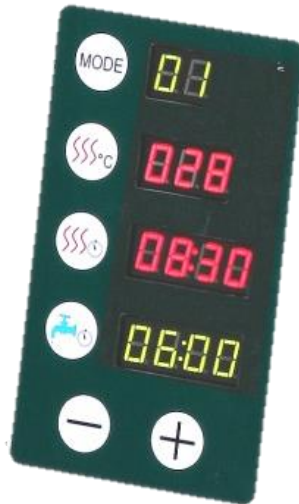

1. Intuitive user interface can set heating temperature, heating time and cooling time.
2. 40 memory modes can set different parameter.
3. Fully auto mounting press.
4. Multi over-temperature protections.
5. Malfunction message would be reported immediately for user to remove problem efficiently



TOP TECH

Worthy Options - Working Table



Working Table

Multifunctional working table, it supplies you a place to put your machine and store your accessories. It can be moved easily.

Model No.	TF01	TF02
Size	1000*690*700 mm	1000*950*700 mm
Sample		



Appendix 1 、 Cylinder kit option

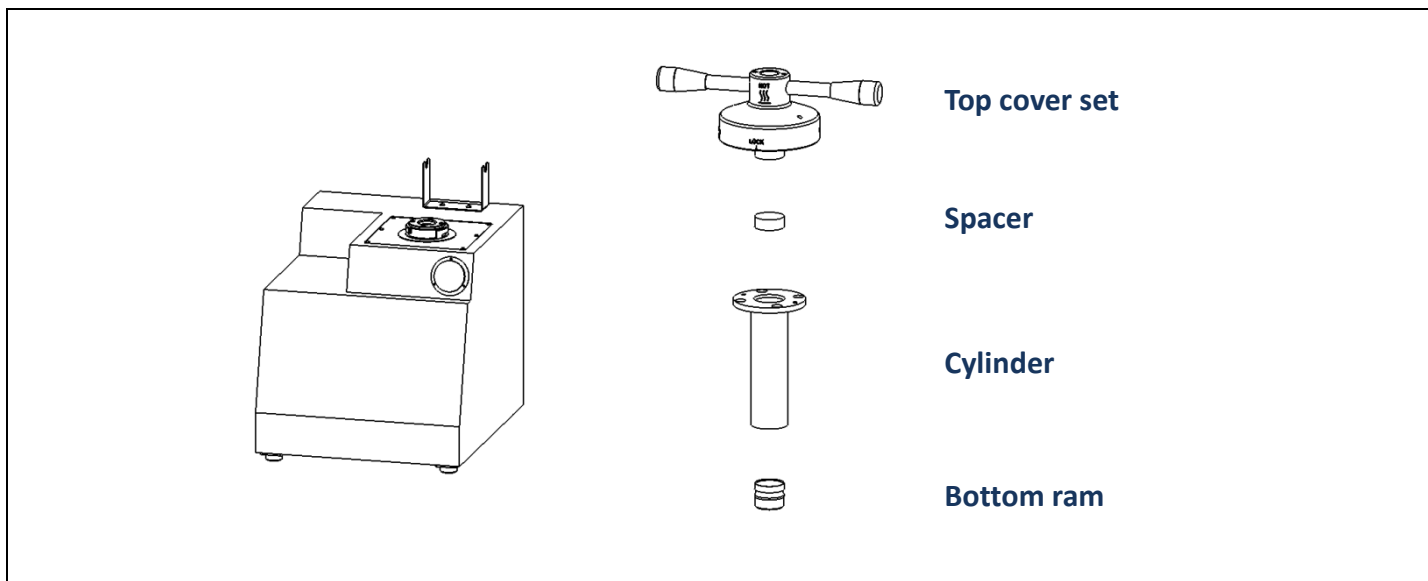

Ø40

Cylinder kit (Single mold)	Size	Ø25	Ø30	Ø32	Ø40
	Order no.	ML40AD0215A	ML40AE0214A	ML40AE0213A	-
Cylinder kit (Three molds)	Size	Ø25	Ø30	Ø32	Ø40
	Order no.	ML40AE0215A	ML40AE0214A	ML40AE0213A	-

Ø50

Cylinder kit (Single mold)	Size	Ø25	Ø30	Ø32	Ø40
	Order no.	ML50AE0216A	ML50AE0215A	ML50AE0214A	ML50AE0213A
Cylinder kit (Three molds)	Size	Ø25	Ø30	Ø32	Ø40
	Order no.	ML40AD0215A	ML40AE0214A	ML40AE0213A	ML40AD0215A

Note 1: Cylinder kit including follow parts.

Single mold: Top cover set 、 Spacer x 1 、 cylinder 、 Bottom ram

Three molds: Top cover set 、 Spacer x 2 、 cylinder 、 Bottom ram

Note 2: Special specification can be ordered.

Note 3: Cylinder size below Ø32mm not able to option inside mold.



Appendix 2 、 Option accessories

Spacer

	Specification	Order on.	
		Copper spacer	Iron spacer
Metric (mm)	Ø25	ML25AE0210-1	ML25AE0210-2
	Ø32	M32C0006-1	M32C0006-3
	Ø38	-	-
	Ø40	M40C0006-1	M40C0006-2
	Ø50	ML50DG0210-1	ML50DG0210-2
Inch (in)	1"	-	M25AE0211
	1 $\frac{1}{4}$ "	M32C0011	M32C0011-1
	1 $\frac{1}{2}$ "	ML38AE0206	ML38AE0206-1
	2"	-	-
Remark	Special sizes can be customized		

Water pump

Order on.	Specification	Remark
QWP06001	1Ø-110V-50/60HZ	
QWP06002	1Ø-220V-50/60HZ	
QWP06002-1	1Ø-200V-50/60HZ	





TOP TECH

Specification

Model No.	B				B-E3			
Sample dia.	Ø25mm	Ø32mm	Ø40mm	Ø50mm	Ø25mm	Ø32mm	Ø40mm	Ø50mm
Driven method	High efficiency motor driven & Hydraulic control							
Sample qty.	1pc/per time- Note1				1~3 pc/per time			
Temperature	0~250 °C (1 °C/unit) – Note 2							
Noise level (idle running)	65~71dB		67~73dB		70~77dB		72~78dB	
Heating power	1200W		1600W		2400W		3200W	
Motor power	1760W		2160W		2960W		3760W	
Heating time	Max.60 minutes							
Cooling time	Max.30 minutes							
Memory mode	40 sets (Can set heating temperature、heating time and cooling time)							
Pressure adding	60 kg/cm ² (852psi)				60 kg/cm ² (852psi)			
Machine size (WxDxH)	58x57x59cm				58x57x70cm			
Weight	80Kg		81Kg		87Kg		90Kg	
Water inlet/outlet pipes	10mm pipes (inner dia.Ø10mm – Outer dia.Ø15mm)							
Cooling System	Electronic water valve connect outside cooling recycle system							
Power supply	AC220V-1 Ø (Special voltage can be ordered)							
Stand accessories	Tweezers : 1pc		Funnel : 1pc		Filter : 1set			
	Spoon : 1pc		Mounting resin : 1kg(2.2lb)		Connector : 2pcs			
	Pipe clip : 6pcs		Screws : 6pcs		Spacer(E3) : 2pcs			
Option	Cylinder kit							

Note 1: Two molds can be produced at same times if option spacer.

Note 2: Special temperature requirement can be customized.

Note 3: Special shape and size requirements can be customized.

We reserve the right of changing design without notice.



TOP TECH

Parameter I

Dimension

B(unit : mm)

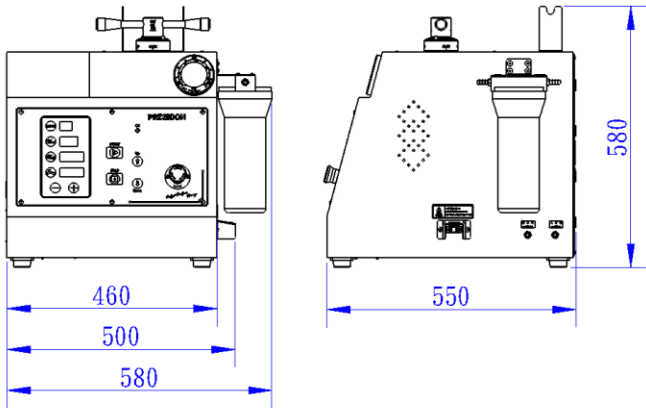

B-E3(unit : mm)

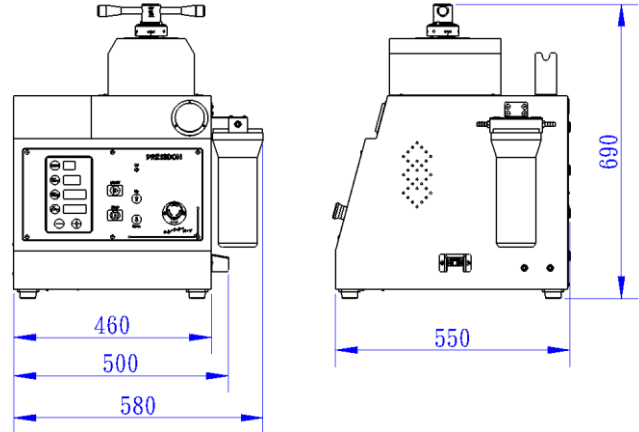

Heating/cooling curve

Note:

1. Sample- \varnothing 32mmx20mm (t).
2. Testing results will be different according to weather condition, materials, sample sizes, and cylinder sizes.

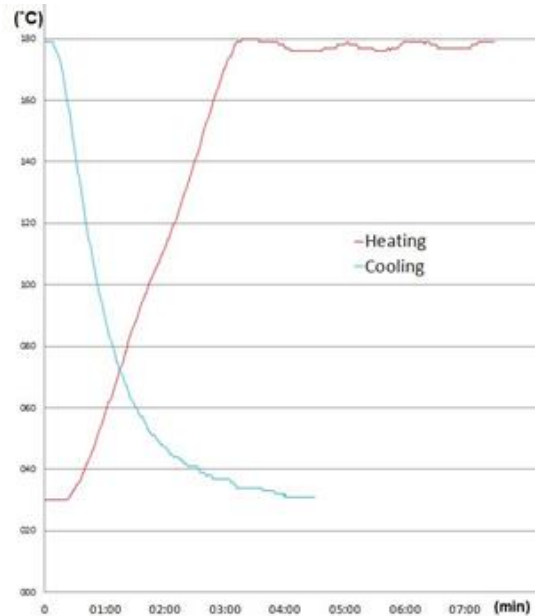

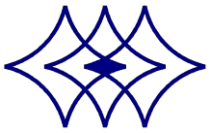

Parameter II

Mold size

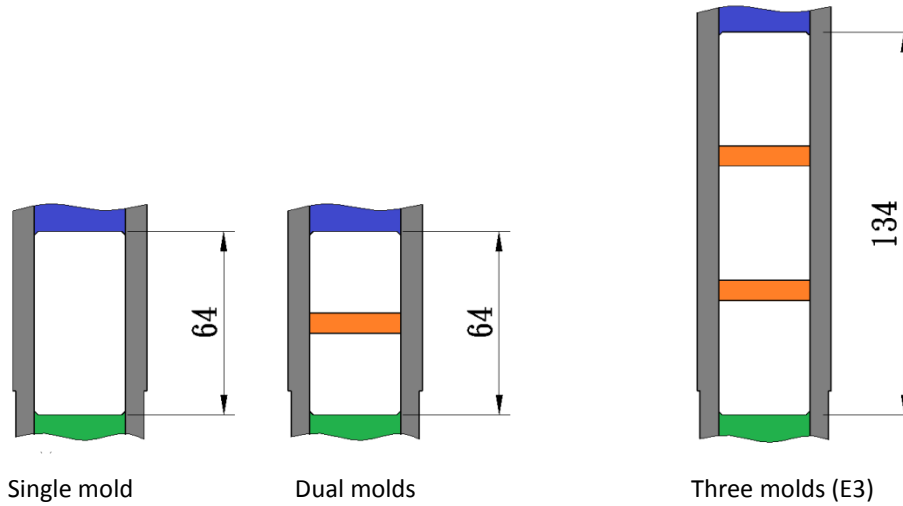

	Mounting size (mm)	Mounting height (mm)	Mounting powder weight (g)	Mold qty.	Mold volume (mm ³)
Single mold	Ø25	21	18	1	10303
	Ø32	21	30	1	16880
	Ø40	21	47	1	26376
	Ø50	21	75	1	41213
Dual molds	Ø25	14	12x2	2	6869
	Ø32	14	22x2	2	11253
	Ø40	14	31x2	2	17584
	Ø50	14	49x2	2	27427
Three molds (E3)	Ø25	18	16x3	3	8831
	Ø32	18	25x3	3	14469
	Ø40	18	40x3	3	22608
	Ø50	18	63x3	3	35325

Parameter III

Mounting pressure comparison table

	Metric system (Kg/cm ²)	British system (psi)
Pressure adding	60	853
Max. pressure	100	1421

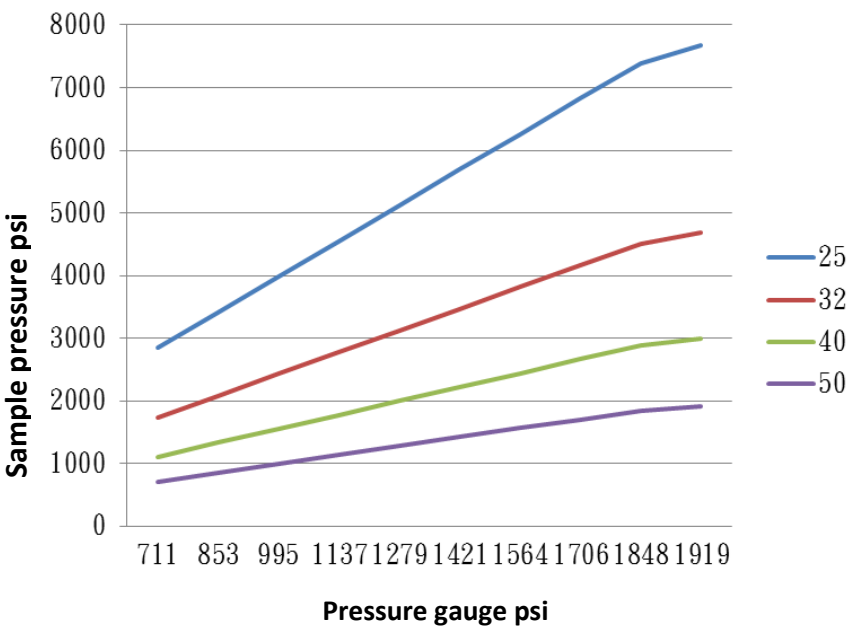
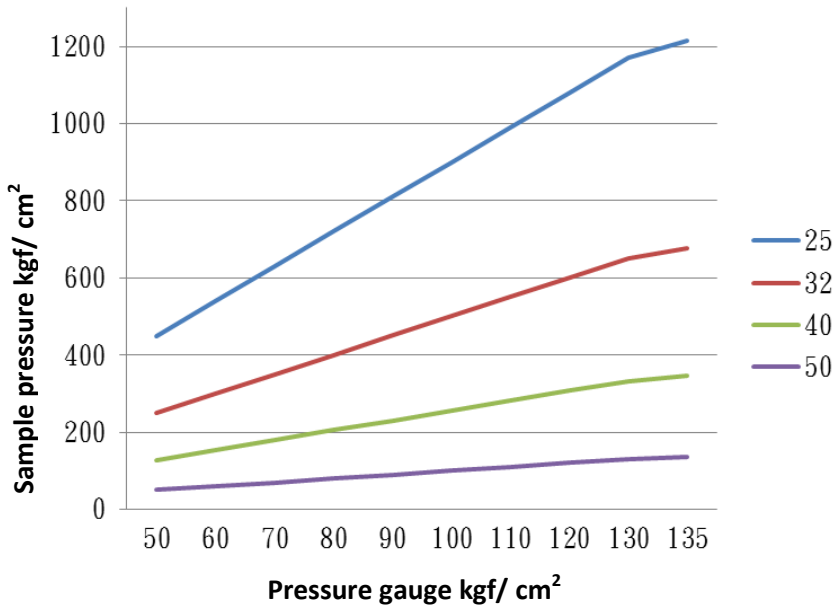

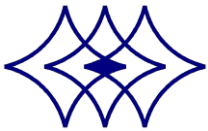



TOP TECH

Consumables

Clear transparent acrylic hot mounting resin

	Order no.	S030109	1 kg
		S030108	2 kg
		S030109-1	5 lb (2.27kg)

Conductive mounting resin, thermosetting, Phenol- formaldehyde resin

	Order no.	S030106	1 lb (0.45kg)
-----------------------------------------------------------------------------------	-----------	---------	---------------

Black bake lite hot mounting resin

	Order no.	S03001	Black-25 kg
		S03001-1	Black-1 kg
		S03002	Brown-25 kg
		S03002-1	Brown-1 kg
		S03002-2	Brown-2 kg
		S03003	Green-25 kg
		S03003-1	Green-1 kg
		S03004	Red-25 kg
		S03004-1	Red-1 kg

Remark: Welcome to get the more detail information of consumables in the follow link

<http://toptech.synology.me/Consumables/MountingEN.pdf>



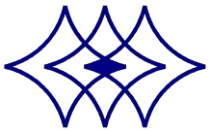

TOP TECH

*Perfect Surface.
Always*

Cutting / Mounting / Grinding & Polishing / Spin Coater

TOP TECH MACHINES CO.,LTD

No.6-3,Siayuan Rd.,Dali,Taichung,412 Taiwan

Tel:886-4-24061658

Fax:886-4-24073200

<http://www.toptech.tw>

<http://toptech.snjapp.com>

E-mail: top@toptech.tw

Agent



We reserve the right to change design without notice.

NO.A16-01

<http://www.toptech.tw>